



Q-TV2

HD SOUND FOR YOUR TV



Q Acoustics - the (amazing) story so far...



Established in 2006, Q Acoustics has been a success right from the start. Its first products, the '1000 Series' shook up the UK loudspeaker industry, received unprecedented praise from reviewers worldwide and scooped prestigious Awards. More Awards followed with the release of the upgraded '1000i Series', but not satisfied with merely designing truly remarkable conventional loudspeakers, Q Acoustics' design team introduced 'Q-AV' the world's first speakers to feature 'BMR' (Balanced Mode Radiator) drive units, enabling for the first time, the whole family to hear perfect home cinema sound, wherever they sat within the room. They impressed 'The Sunday Times' so much they said: "Some day all speaker systems will be like this" (January 2008).

Now Q Acoustics introduces 'Q-TV2', an innovative, technically advanced solution which enhances your complete enjoyment of TV, movies and music in your home, without intruding into your living space.

For the full range of Q Acoustics products please visit www.Qacoustics.co.uk



Q Acoustics 1050, Awards 2006



Q Acoustics 1010



Q-AV, July 2008



Q-AV, June 2008



The Problem: bigger better picture - poorer thinner sound!

New flatscreen TVs are getting bigger and better. They produce crystal clear, pin sharp images and their sleek, stylish, space saving designs have wide-ranging appeal. Yet like most things there's a compromise - as screens get slimmer, sadly the sound they produce has also got thinner.

The Solution: only two choices

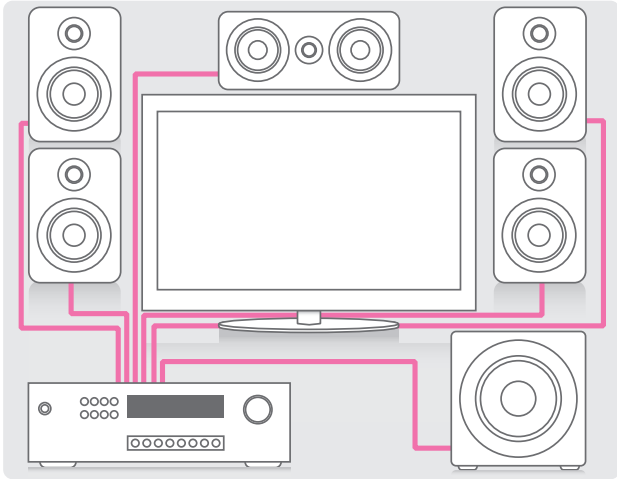

A) Home cinema system: AV Receiver, traditional speakers, a subwoofer and lots of wires.

For: Great sound.

Against: Separate amplifier required, difficult to install and lots of wires.

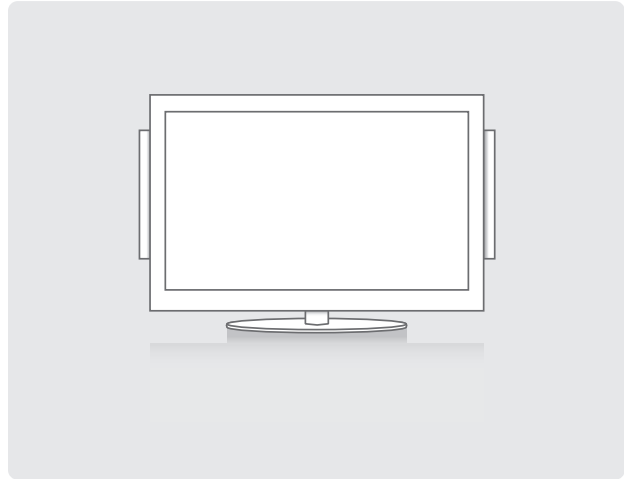

B) Q Acoustics Q-TV2. Affordable, ultra discreet, 2.1 self contained 'plug and play' 100 watt speaker system.

For: Great sound.

Against: Absolutely nothing!

Truly discreet 2.1 HD sound

Born out of a passion for perfection, the Q-TV2 will transform the way you enjoy your TV. The first truly discreet, 2.1 HD Sound upgrade for flatscreen televisions, Q-TV2 delivers dynamic, room filling stereo sound with real bass, yet is completely clutter-free with almost no visual intrusion into your living space.

Unobtrusive and supremely easy to install, it boasts 100 watts of amplification, driving eight advanced technology loudspeakers in stylish stereo enclosures and an integrated vibration-free, ultra-slim subwoofer.



Not just for TV sound

– with Q-TV2 your TV becomes the heart of a real hi-fi system.

Experience wonderful, dynamic movie soundtracks from your DVDs.

Play CDs on your DVD player and hear full stereo sound.

At last you will be able to enjoy the quality of a wide selection of noise free digital radio stations from your TV, as well as bring computer games to life for the whole family.

Lastly, we didn't forget iPods/MP3 players', there's a spare input so you can play these through Q-TV2 as well.



How does it connect?

The simplest way is connect Q-TV2 to the TV's headphone socket. The volume of Q-TV2 is then controlled from your standard TV remote control and is completely seamless in operation. If this is not possible, then Q-TV2 can connect via the television's audio or optical outputs and the volume varied by the Q-TV supplied remote control.

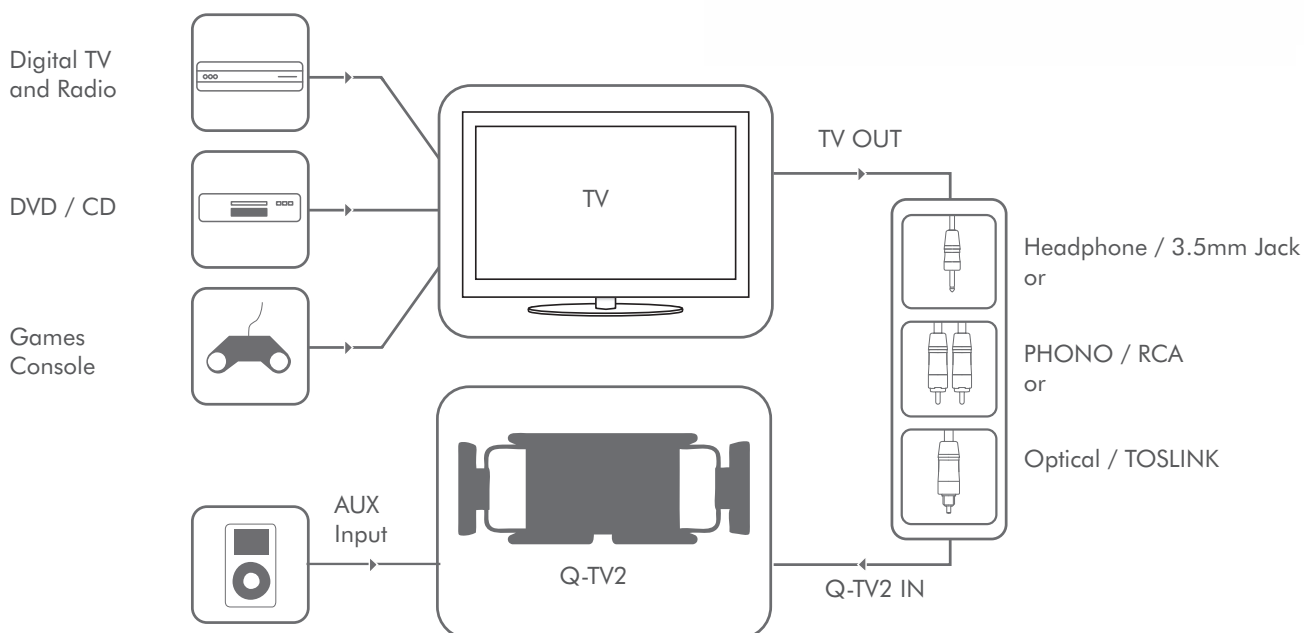

Effortless

Q-TV2 is completely 'plug and play'. It's incredibly easy to install and everything you need is included in the box, nothing extra is required. Connection and adjustment are simplicity itself using the cable and allen key supplied.

Vertical adjustment



Horizontal adjustment



Adjusts to fit any 30" - 42" screen

Q-TV2 Features:

- **Upgrade your TV experience and enjoy HD Sound**

- 100w 2.1 Stereo system
- Ultra-slim, vibration-free subwoofer
- 'BMR' drivers for wide sound dispersion

- **One size fits all**

- Adjusts to fit any 30" to 42" screen

- **Plug and Play**

- Simple to connect
- No speaker cables required
- 3 x EQ setups to suit environment

- **Easy to use**

- Uses existing TV remote
- Auto standby when not in use (with low power consumption)

- **Auxiliary Input**

- Connect an iPod or other personal audio player

- **Digital 'Lip-Sync' adjustment**

Q-TV2 TECHNOLOGY



The same great sound wherever you sit

Q-TV2 uses 'BMR' (Balanced Mode Radiator) loudspeaker drive units which not only deliver outstanding sonic performance, but also disperse the sound across an exceptionally wide area. This means, wherever you sit in your listening room, you'll still enjoy the full hi-fi or home cinema experience.

Additionally, because the advanced BMR drive units in Q-TV2 are very narrow (only 29mm x 131mm) Q Acoustics' design team have been able to make the whole system incredibly slim. Astonishingly, the subwoofer is only 38mm deep and easily hidden when mounted on the rear of the TV screen.

Conventional Driver



BMR™ Driver



What! No vibration from the subwoofer?

That's right; thanks to Q Acoustics' brilliant engineers, there isn't any vibration. The subwoofer is fully 'Force Cancelling', which means all vibrations and resonances are minimised.

Will room position affect the sound?

Out of the box, Q-TV2 comes set to deliver its optimum performance in a 'free-standing' position, mounted on a TV away from a wall. If your TV is positioned close to a wall, or in a corner, that will give bass frequencies a boost. Q-TV2 is equipped with a three position tone switch to compensate for this.

'Lip-sync' - video delays?

The video processing which takes place inside some 'set-top boxes', DVD players and the like, may cause delays to video signals, leading to 'lip-sync' problems. Naturally, Q-TV2 boasts 'variable delay' to overcome any such problems.



Q-TV2 MOUNTING OPTIONS



TV Mount (included)

The Q-TV2 attaches to the rear of the screen and is supported by the existing table stand supplied with your TV. Using the two vertical mounting rails supplied, the Q-TV2 bolts to the rear of your screen.



Wall Mount (optional)

An optional wall bracket is available. This holds both the screen and Q-TV2 flat to the wall. The wall to screen depth is kept to a minimum.

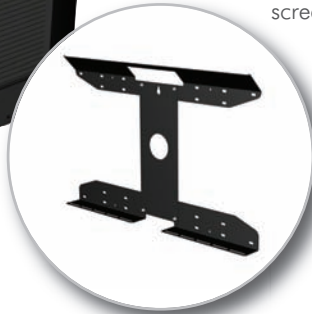

Cantilever Bracket (optional)

The Wall Mount can be attached to a Cantilever Bracket, enabling both screen and speaker system to be angled towards your preferred viewing position.



TECHSPEC

Q-TV2

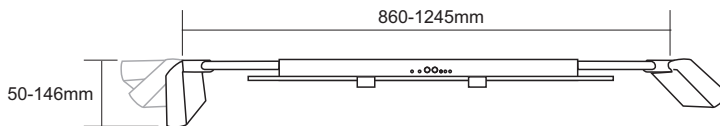
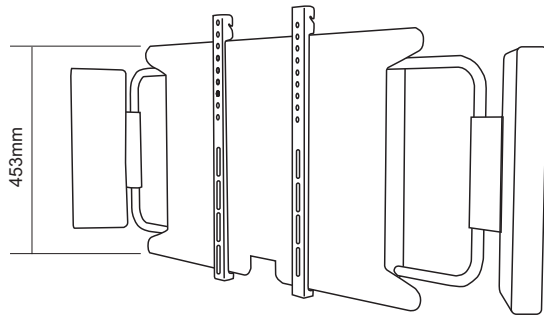

Wall Mount

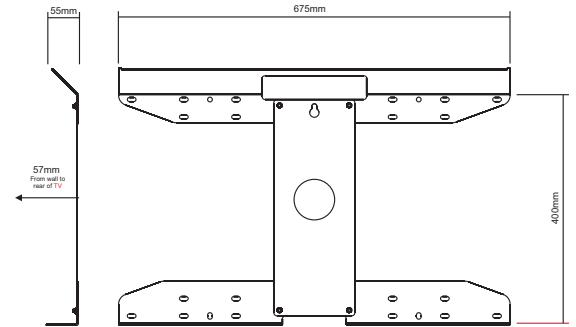

Cantilever Bracket (Wall Mount Required)

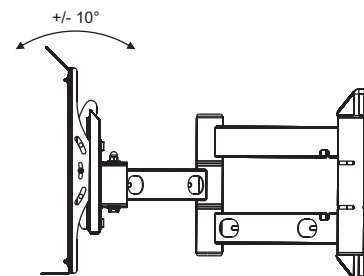
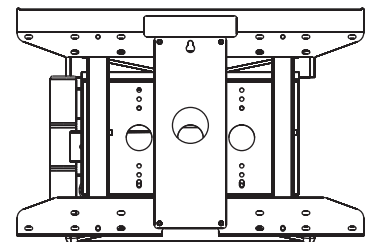
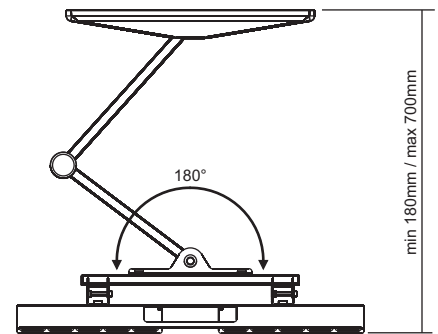

Specifications:

Satellites

Speaker type:	Sealed box with wide dispersion
Drivers:	2 x 15w 3cm x 12cm Balance Mode Radiator
Frequency Response:	(+/- 3dB) 180Hz – 20kHz
Power:	25Wrms per satellite

Subwoofer

Speaker type:	Force cancelled bass reflex with dynamic EQ
Drivers:	4 x 15w 3cm x 12cm bass driver
Frequency Response:	(+/- 3dB) 50Hz – 180Hz
Power:	50Wrms

armourHOME

Armour Home Electronics
Stortford Hall Industrial Park
Dunmow Road
Bishops Stortford
Hertfordshire CM23 5GZ

Tel: +44 (0) 1279 501111
Fax: +44 (0) 1279 501080
www.armourhome.co.uk
info@armourhome.co.uk



www.Qacoustics.co.uk

AHE1159 // ZB 0263U

Our policy is one of continuous product improvement, we reserve the right to change the designs and specifications without notice. All information is given in good faith. The manufacturer accepts no responsibility for errors, omissions or incorrect assumptions. Armour Home Electronics 2009. E&OE.